

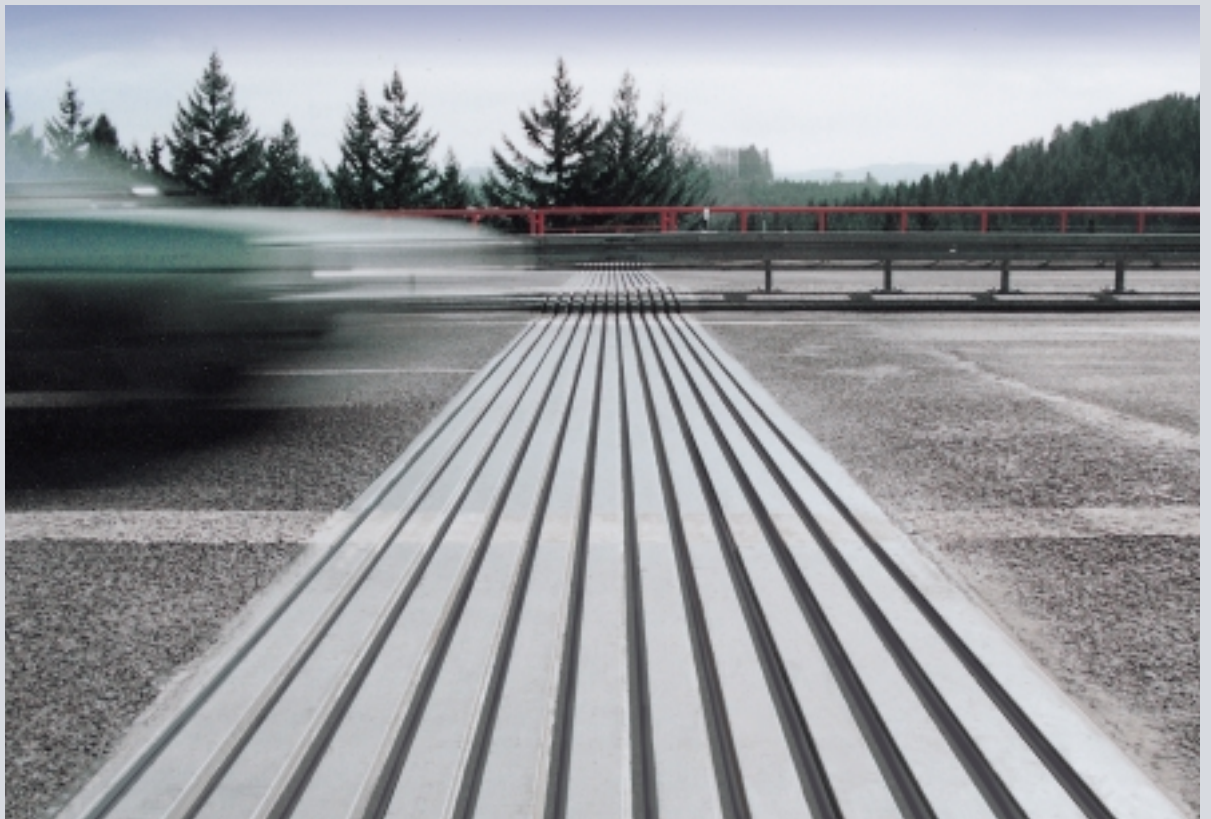

MAURER Girder Grid Joints



MAURER Modular Expansion Joints

Girder Grid Joint
type D 560



More than 1.000km of MAURER Modular Expansion Joints are in place worldwide, this figure making us one of the leaders in Europe and Overseas in the field.

The basis for the design of this long-life and practically maintenance-free modular system is more than 30 years of research and development in close liaison with established technical universities and leading scientific institutes, proving its capability of withstanding extreme loading whilst being practically maintenance-free.

MAURER Modular Expansion Joints are designed for road and railway bridges, parking decks, buildings, ramps, footway bridges, airports and many other facilities; among them such prestigious structures as

- River Rhine Bridge A 42 near Duisburg/Germany
- Storebælt East Bridge and Oresund Bridge, Denmark
- Vasco da Gama Bridge, Portugal
- Jiangyin Yangtze River Bridge, China

Expansion joints have the task of bridging structural gaps by complying with the following requirements:

1. Accommodation of loads and movements by
 - safe transmission of traffic loads
 - rigid and shallow anchorage in the structural components
 - low detriment to carriageway surface
 - continuous adaption to deformations in the structure
 - low resistance to deformation
2. Durability of joint system and its adjoining components due to
 - absolute watertightness
 - high fatigue strength
 - resilience, i.e. unrestrained and damped support of all movable components
 - use of materials resistant to aging, corrosion and wear
 - maintenance-free design
3. Low noise emission under traffic due to
 - avoidance of surface irregularities
 - sealing elements, which are not subjected to traffic loads
 - preloaded bearing components made of high-grade synthetics.
4. Efficiency

Stress optical investigation into the connection centre beam – support bar at the technical university of Innsbruck

MAURER Modular Expansion Joints

MAURER Modular Expansion Joints comprise of steel centre beams arranged in the longitudinal direction of the joint with interposed strip seals. Due to individual gaps being restricted in width several strip seals must be employed in series to accommodate greater movements. Accordingly one or more centre beams are required between the edge beams, supported on cross bars movably arranged at one or both edges of the structural gap.

MAURER Girder Grid Joints

In the MAURER Girder Grid Joint each centre beam is rigidly welded to its assigned support bar, thus resulting in a girder grid which is capable of moving within itself. Control springs arranged between the support bars control the spacing of the centre beams as a function of the overall width of the structural gap.

The support bars are aligned in the direction of movement of the structure. Movements deviating from this arrangement can be accommodated to a limited degree.

This straightforward and, therefore, reliable design is highly economic when a certain number of sealing elements (2 to 8) is not exceeded.

In situations where limited space is available on one side and the movement range is unusually large or when movements have to be accommodated in differing directions or for extending the application range of MAURER Modular Joints the MAURER Swivel Joist Joint is the alternative.

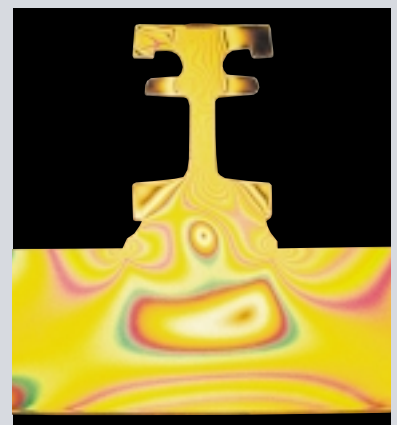

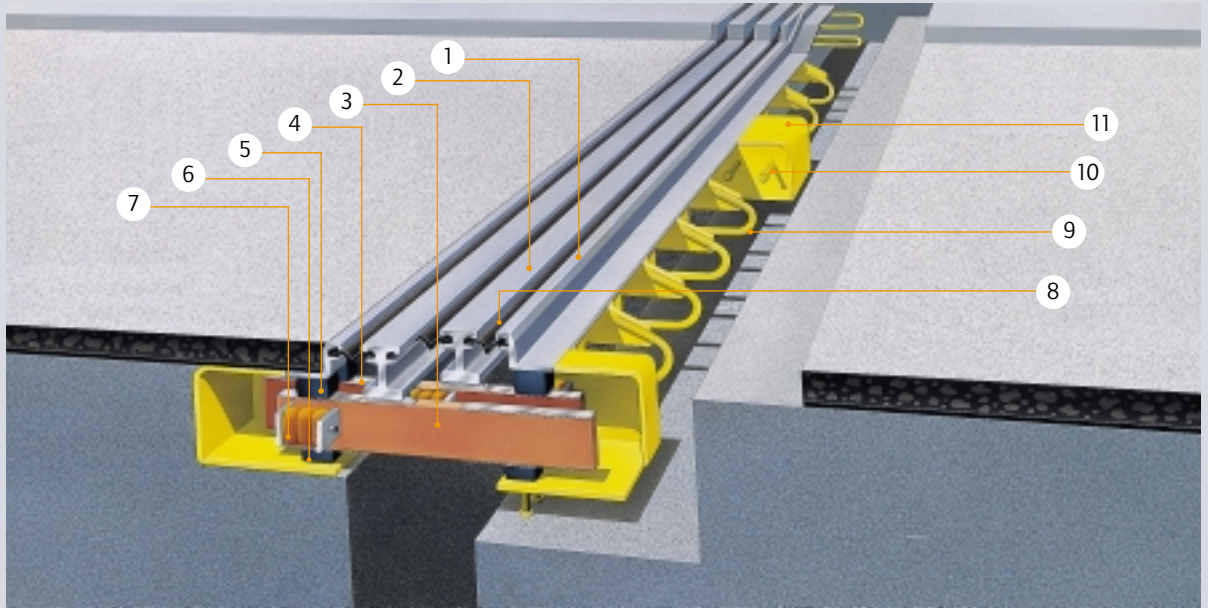

Technical approval and independent periodical inspection acc. to TL/TP-FÜ



Continuous in-house and field quality control, the use of high-grade materials and a quality assurance system in keeping with ISO 9001 and EN 29001 ensure the high standard of MAURER Girder Grid Joints.

All design elements of MAURER expansion joints are engineered in high-quality materials. All synthetics used feature excellent resistance to aging, wear and the environment. Relaxation of the control and bearing elements is insignificant even after decades of service. The sealing elements are insensitive to physical stress.

National regulations are to be taken into account in the choice of the corrosion protection system. We recommend using two-part zinc-rich paint as the primer and epoxy-based micaceous iron as the finish.

Designation	Description
Supporting Elements	
1 Edge Beam	Hot-rolled section of steel grade S 235 JR G2 precision tolerances combining good weldability with notch toughness. Can be both shop and site butt-welded.
2 Centre Beam	Hot-rolled section of steel grade S 355 J2 G3 precision tolerances combining good weldability with notch toughness. Can be both shop and site butt-welded by patented system.
3 Support Bar	Steel grade S 355 J2 G3, machined for precision tolerances.
Supports	
4 Sliding Plate	Stainless steel in bridge bearing quality. Sliding surfaces ground and polished. Material no. 1.4401.
5 Sliding Spring	Natural rubber steel laminated, vulcanized in place. Sliding surfaces of PTFE.
6 Sliding Bearing	Chloroprene rubber with steel spherical inlay vulcanized in place to handle tilt loading. Sliding surfaces of PTFE.
Control Elements	
7 Control Spring	Cellular polyurethane of high tear strength, insensitive to oil, gasoline, ozone. High resistance to aging, high self-damping.
Sealing Elements	
8 Strip Seal 80	Chloroprene rubber or EPDM with high tear strength, resistant to salt water, oil and aging, available in any length. Can be vulcanized in place on site.
Anchorage	
9 Carriageway Anchor	Steel plate and loop from S 235 JR G2.
10 Anchor Stud	St 37K
11 Support Box	To accommodate the sliding bearings, sliding springs, control springs and support bars.

Load Transmission, Fatigue Strength, Riding Comfort and Traffic Safety



Safe Load Transmission

Vehicles travelling over the expansion joint transmit vertical and horizontal loads to the centre beams. The section forces resulting from the eccentric wheel loads are transmitted to the support bars by means of the centre beam. This beam acts as a continuous girder. From there they are diverted into the edges of the structure via the supporting elements and control springs.

The edge beam is rigidly anchored in the structure. For fatigue reasons the traffic loads are transmitted via anchor plates into the adjacent reinforced concrete construction. The support boxes are equipped

Load transmission at the centre beam

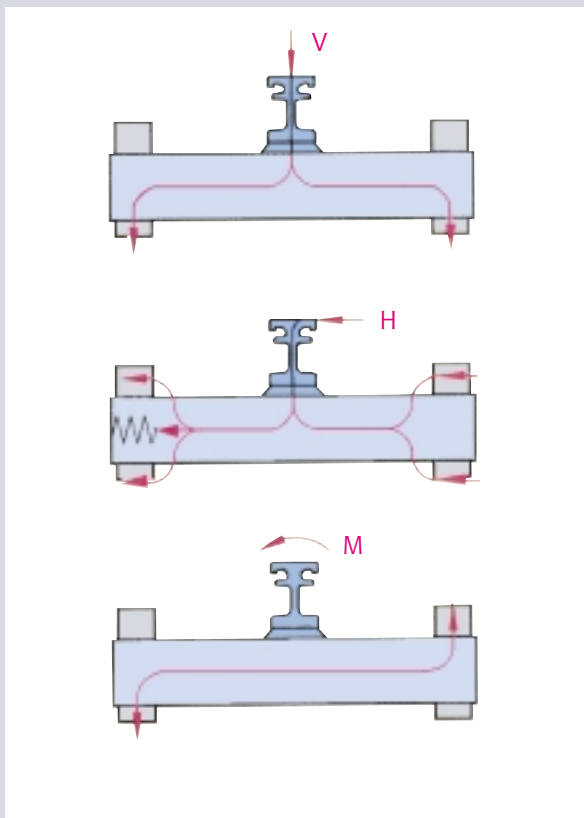

with anchor studs for rigid connection to the adjacent concrete. In the case of steel bridges the edge construction is supported on consoles or supporting girders parallel to the end cross girder.

Riding Comfort and Traffic Safety

Due to the relatively small expansion joint surface exposed to traffic compared to the movements to be accommodated, the riding comfort is excellent.

The steel surface of the joint divided into small gaps requires no additional treatment to make it skid-proof.

Tests have shown that no significant increase of the impact effect by the tyre occurs up to a single gap width of 80 mm for modular expansion joints. However, it is particularly important that a flush interface is provided between the road surface and the expansion joint.

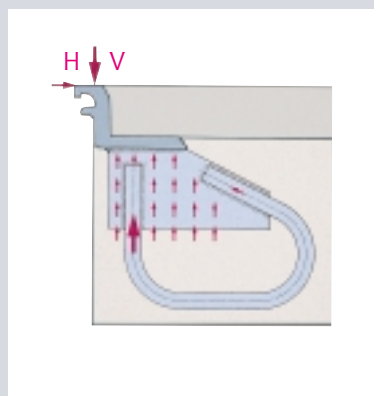

High Fatigue Strength

Expansion joints are subject to high dynamic stresses due to vehicle loads.

Whilst demonstrating the safe load carrying capacity by structural analysis gives a theoretical indication of the suitability of an expansion joint. Proving its fatigue strength is mandatory in estimating its lifetime. Expansion joints are subjected to intensive axle loading.

In field tests the precise load deformation behaviour was measured for various test situations (braking, starting, driving over) and under normal traffic conditions, from which reliable static systems were established to find out how components are stressed under wheel loads.

To regulate the various notch categories the fatigue behaviour was determined on all components of the system in the lab using load combinations approximating to that of actual conditions.

Anchorage of the edge beam

Versatility

Designing an expansion joint is governed by the magnitude and direction of the main movement of the structure in the plane of the carriageway, this being determined in a girder grid joint by the number of expansion gaps and the arrangement of the support bars running parallel to this direction, whereas the edge and centre beams are located parallel to the edges of the structure.

In addition to the normal anticipated movements in the plane of the carriageway, a multitude of secondary movements can occur.

E.g. rotations φ_z due to irregular increases in temperature, movements u_y due to abutment settings and the resilience of neoprene bearings, movements u_z resulting from cantilever bridge ends. Also to be taken into account are movements u_z resulting from jacking up the superstructure, for instance, when replacing bridge bearings and from the difference between the longitudinal inclination of the carriageway and the horizontal arrangement of the bearings.

The MAURER Girder Grid Joint is capable of handling all such movements safely.

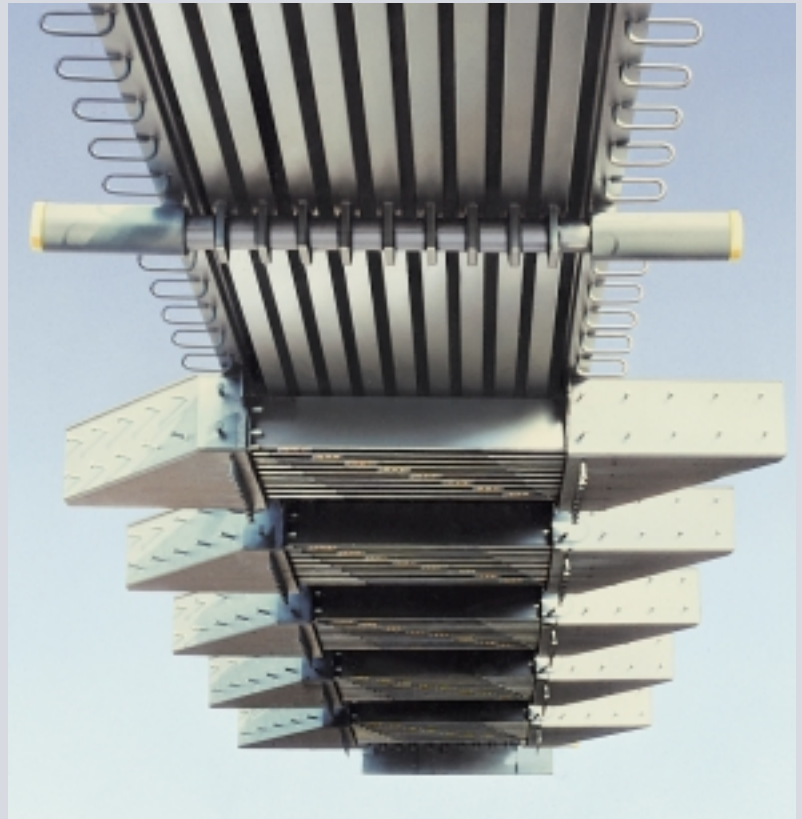

Designing and dimensioning expansion joints in Germany is dictated by the TL/TP-FÜ (Technical Delivery Instructions and Test Specifications) of the Federal Ministry of Transport. MAURER Girder Grid Joints are approved accordingly and are subjected to independent periodical inspection.

To determine movements accord to German Standard DIN 1072 consideration has to be given to a combination of the following factors:

- thermal effects
- prestress
- shrinkage and creep
- superstructure deformations
- substructure deformations

The following extreme temperature ranges govern the design of expansion joints in addition to normal bridge design consideration:

1. For steel and steel/concrete bridges +75°C/-50°C
2. For concrete bridges and bridges with rolled beams concreted in place +50°C/-40°C

The expansion joint design can be finalised on the basis of site temperature measurements prior

to installation and following final connection of the structure with the fixed bearings. The extreme temperature values can then be reduced by

- ±15°C for bridges according to (1) and
- ±10°C for bridges according to (2)

The functional range of the strip seals is 0 thru 80 mm perpendicular to the joint (u_x) and -40 mm thru +40 mm parallel to the joint (u_y).

All MAURER expansion joints are designed to take movements of 80 mm per joint gap and thus the type designation results as a multiple of 80. According to the requirements of ZTV-K (Additional Technical Contract Provisions for Engineering Structures) a movement range of 5 to 70 mm, thus 65 mm, is allowed in Germany. This limiting value applies measured perpendicular to the joint axis.

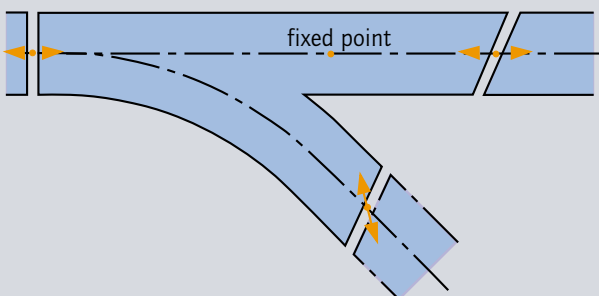
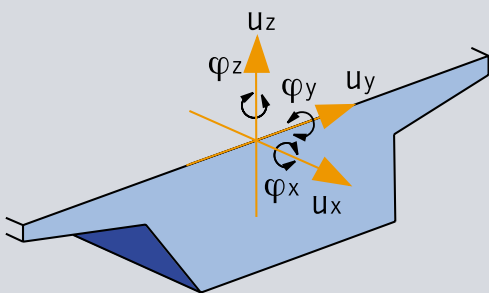

Concrete Bridge

typical cross-section and plan view for anchorage in reinforced concrete

Cross-section

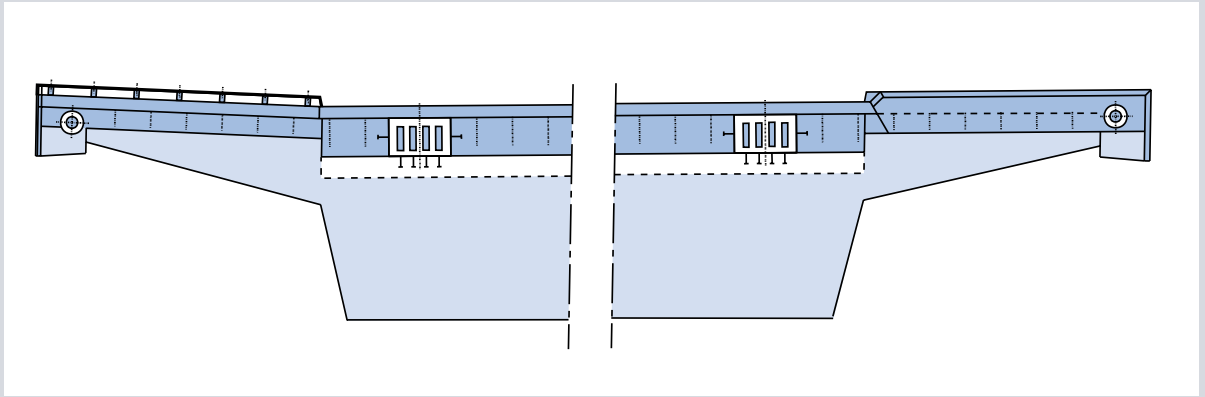

Plan view

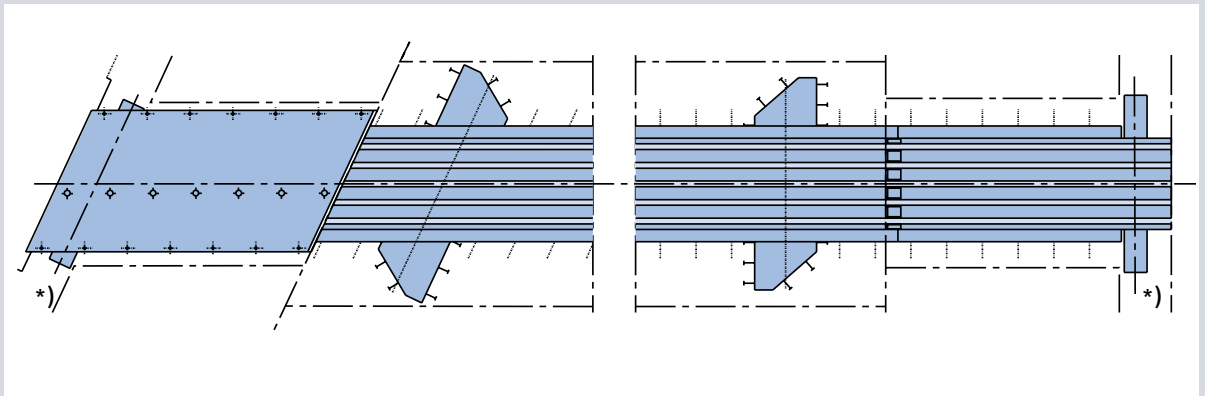

Anchoring in concrete structures is governed by the design data as tabulated beside.

For steel structures our engineering offices formulate solutions tailored to individual requirements.

Salient design features can be seen from the following figures:

Steel Bridge

Design alternatives for connection to steel decks

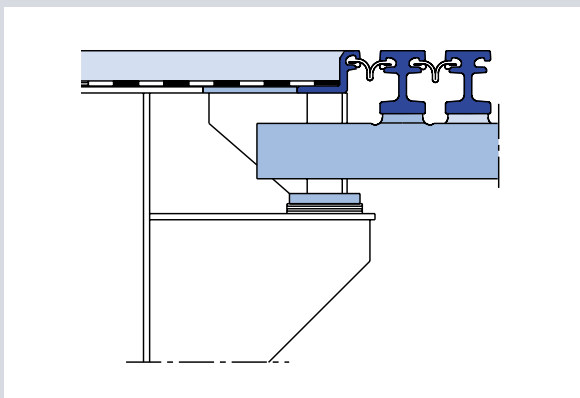

Support on single cantilever

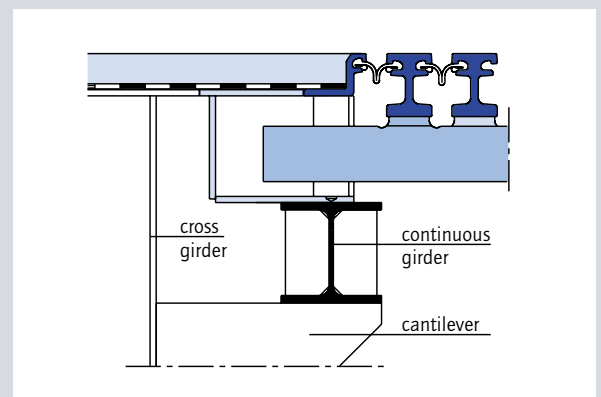

Support on continuous girder

Cross-section
thru carriageway
at support box

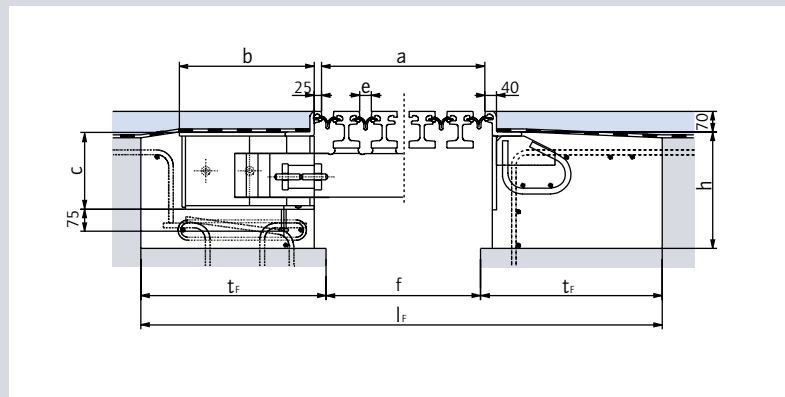

Cross-section
thru carriageway
between support
boxes

Cross-section
thru footway
(alternative 1)

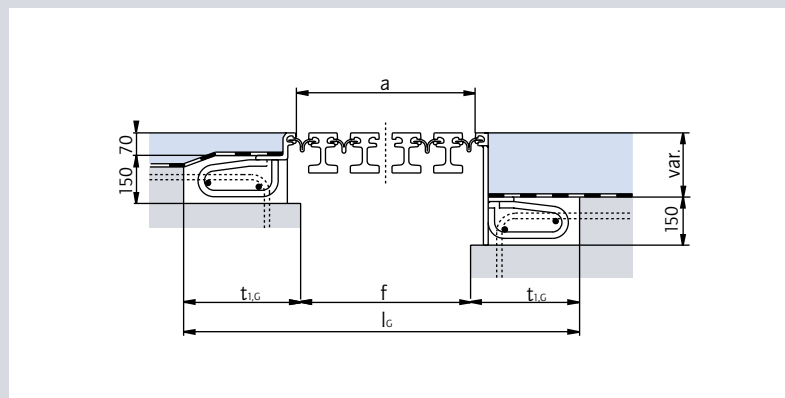

Cross-section
thru footway
(alternative 2)

Cross-section
thru footway
with strip seal
80 G without
footway cover
plate

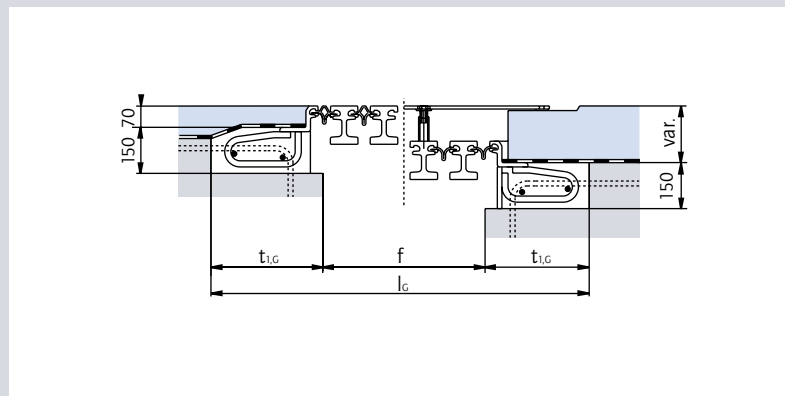

Cross-section
thru footway
with cover plate

Cross-section
thru footway
guide unit
(alternative 1)

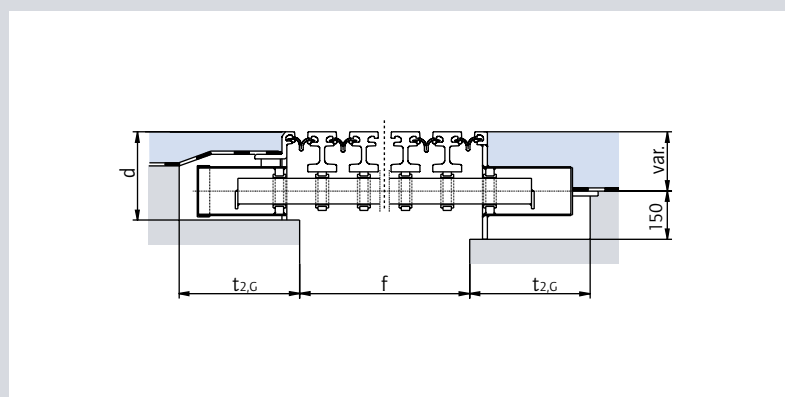

Cross-section
thru footway
guide unit
(alternative 2)

Design and Product Data

The form of reinforcement shown is merely a proposal. For reinforcement in the area of the carriage-way and footways we recommend a hoop-shaped reinforcement of weldable 16 mm dia. rebar on a centre-spacing of 200 mm in conjunction with longitudinal reinforcement of the joint and a mesh reinforcement of the gap beneath the joist boxes.

The total movement "u" in the main direction of movement can be resolved into the two components u_x and u_y perpendicular and parallel to the direction of the joint respectively. Selecting the size of joint is governed by the component u_x and the maximum permissible gap width.

To assist dimensioning, the salient design data is listed in the table, whereby departures are possible within certain limits where space availability is restricted. All dimensions are nominal and will be determined according to project. These dimensions are measured at a right angle to the axis of the joint and for angles α of 45° to 90° between this axis and the direction of movement. Dimensions for smaller angles or larger movements are available on request.

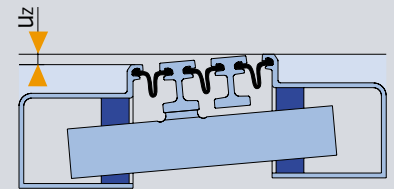
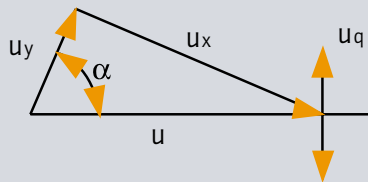
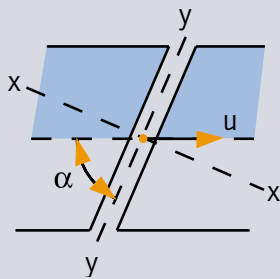

preliminary gap dimension e = 30 mm (all dimensions in mm)																	
MAURER expansion joint			admissible movement			design data				concrete recess dimensions				concrete gap dimensions			
n	type	a[°]	u_x	u_q	u_z	a	b	c	d	h	t_F	$t_{1,G}$	$t_{2,G}$	f_{min}	f_{max}	l_F	l_G
2	D160	90°-45°	160	±10	±20	150	217	216	255	340	350	335	335	150	200	850	820
3	D240	90°-60°	240	±15	±30	270	297	226	255	350	430	355	355	240	320	1100	950
		59°-45°						246		370							
4	D320	90°-60°	320	±20	±40	390	377	246	275	370	520	365	365	350	440	1390	1080
		59°-45°						266		390							
5	D400	90°-60°	400	±20	±50	510	509	266	275	390	650	375	375	460	560	1760	1210
		59°-45°						525	286	410	680					1820	
6	D480	90°-60°	480	±20	±60	630	588	286	285	410	745	385	400	570	680	2060	1340
		59°-45°						606	306	430	760					2090	
7	D560	90°-50°	560	±20	±70	750	682	306	285	430	800	395	450	680	800	2280	1470
		49°-45°						687	326	450	850					2380	
8	D640	90°-60°	640	±20	±80	870	749	306	285	430	890	405	500	790	920	2570	1600
		59°-45°						767	326	450	940					2670	

n... number of sealing elements
 u... moving direction at superstructure
 u_x ... movement rectangular to the joint axis
 u_y ... movement in joint direction ($\leq \pm n \times 40$ mm)
 u_z ... vertical adjustment of the edge beams in direction z
 u_q ... crosswise movement rectangular to u
 α ... angle between joint axis y and moving direction

- all dimensions are rectangular to the joint axis y
 - a, f and l apply to an adjustment dimension e = 30 mm for every joint gap and must be adjusted by $n \times \Delta e$ in case of deviating dimension
 - recesses for footway joists and pipe passages must be considered individually
 - smaller gap dimensions by specific structural design
 - the gap recess t can be reduced by installing the joint at one edge asymmetrically to the joint

type	weight (kg/m)
D 160	200
D 240	290
D 320	400
D 400	530
D 480	680
D 560	830
D 640	1040

Resilient Control, Resilient and Prestressed Support

Resilient Control

MAURER Girder Grid Joints adapt continually to deformations in the structure. The control springs provided between the support bars ensure a uniform distribution of the total movement to the individual joint gaps. Steel stops are provided at the support bars to prevent an opening of the individual gap of more than 80 mm.

The springs comprise mainly of closed-cell polyurethane, a material which has a proven record of success for spring elements exposed to dynamic and impact stresses. The high permissible deformation (up to 80% compression deformation relative to the original free length) permits the production of elements with high permissible spring deflection for a compact design. The natural damping effect of the material affords vibration and impact damping of dynamically stressed components.



Control of MAURER Girder Grid Joints

The special arrangement of the stops for securing the control springs to the support bars has the effect that the wider the opening of the joint the more the springs are compressed. The springs are compressed in any opening condition of the joint, the precompression being at a minimum when the joint is closed. Advantages of this control system are as follows:

- adaptability to production tolerances
- high reliability
- durability
- insensitive to movement constraints
- noise damping
- single gap increase possible during repair

The reaction forces resulting from the elastic deformations of the strip seals and the control springs are independent of how many of these parts are involved because they function as a series arrangement of springs.

Resilient and Prestressed Support

The support bars of the MAURER Girder Grid Joint are supported by resilient bearing elements i.e. precompressed spring and sliding bearings, located above and below the support bars respectively in the support boxes. This arrangement provides a resilient and sliding support in the direction of the structure movement. Pre-compression of the sliding springs prevents the supports from lifting off the bearings and also compensates for manufacturing tolerances. The support resilience also serves to eliminate edge pressure in the sliding surfaces.

To compensate for unavoidable differences in height between the edges of the structure, the sliding bearings have been designed to accommodate the resultant inclination of the support bars and to reduce the torsional stiffness.

The Control Principle

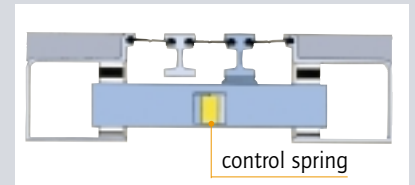

Opened joint, cross-section

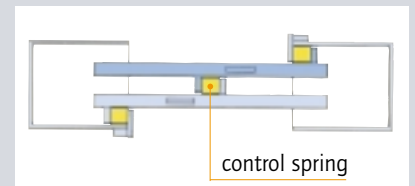

Opened joint, plan view

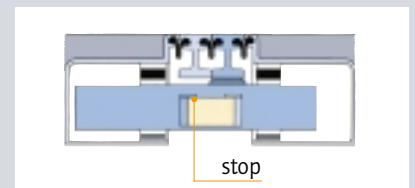

Closed joint, cross-section

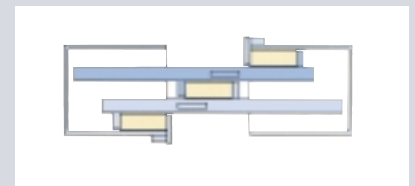

Closed joint, plan view

Watertight Connection, Installation, High Functional Reliability and Low Noise Emission

Watertight Connection

To protect the adjacent structural parts from the penetration of dirt and aggressive surface water MAURER Girder Grid Joints feature watertight strip seals to close the gap between the individual steel beams watertight. The MAURER strip seal has become most popular in modular seals systems.

The strip seal is made of EPDM rubber with a bulbous-shaped edge. This is installed in a claw in the edge beam and centre beams without the need for additional clamping bars. The connection is watertight and secure, with the peeling element set below the road surface level. It is protected against direct wheel or snowplough contact.

Deformation features of the strip seal



40 mm gap width, mid position



80 mm gap width, max. position

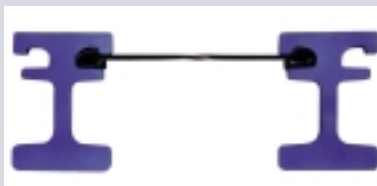

150 mm gap width, over-expanded position

With its preformed articulated section it is possible to move the strip seal in direction x without any appreciable build-up in reaction forces. Movement in direction z causes deformation of the sealing element.

Sealing elements can be replaced even when the individual gaps are ≥ 25 mm. The gap width can be enlarged by moving the centre beams. This operation is carried out using special hydraulic equipment.

The bulbous edge section of the sealing element locks it in the steel claw and is capable of withstanding wheel pressure on any impurities (e.g. stones, grit, snow etc.).

The sealing element adapts to different kinds of joint design and bridge cross sections.

For the protection of the structural concrete and the substructures the interface of the edge beams to the waterproofing layer(s) of the bridge must also be watertight. For this purpose the edge beams of MAURER Girder Grid Joints feature an 80 mm wide horizontal steel flange.

Installation

Installation is usually realized by our special fitters and according to the valid work instructions.

High Functional Reliability

Within their anticipated lifetime no malfunction of MAURER expansion joints is expected, but despite this, all synthetic components can be replaced with minimum effort. Touching up the corrosion protection system is required during maintenance as is normal for steel structures.

Low Noise Emission

Carriageway expansion joints also add to this noise, the causes of which have been investigated in extensive research by Maurer Söhne to enable MAURER Girder Grid Joints to be optimized in this respect.

Residents in the vicinity of such expansion joints find the sudden change in the noise pattern particu-

Insertion of strip seal into the edge beam

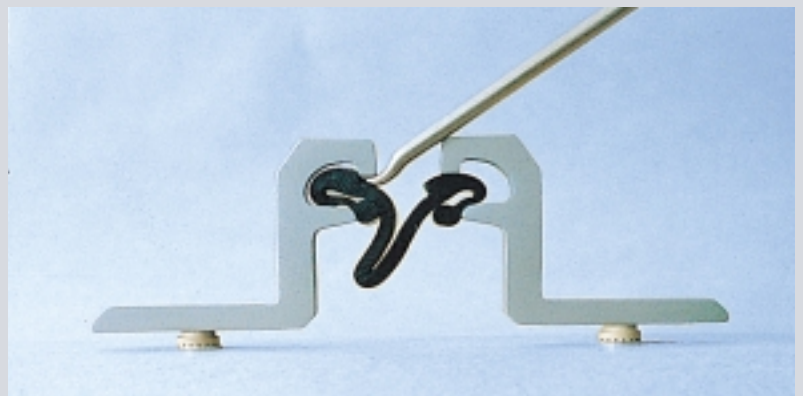

larly disturbing, the criteria for which is not so much the noise level as measured but the magnitude of the fleeting change in frequency and the pulsed element of the noise pattern, whereby a basic distinction is made between noise emitted upwards from the carriageway and the noise projected downwards through the gap between the two structural components.

All supporting elements of MAURER Girder Grid Joints which are exposed to traffic loads are supported by high-quality resilient synthetics which distinguish such designs from those having rigid support. The structural gap can be dammed downwards. Maurer Söhne offers tailored solutions for each and every application.

Noise control to the top is effected by optimizing the road surfacing connection and supporting the wheel when crossing the joint. Angular joint design, finger-type bridging and joint sealing afford relief.

Detail Features

Watertight design of parapet



Horizontal bend and kerb units



Special kerb unit

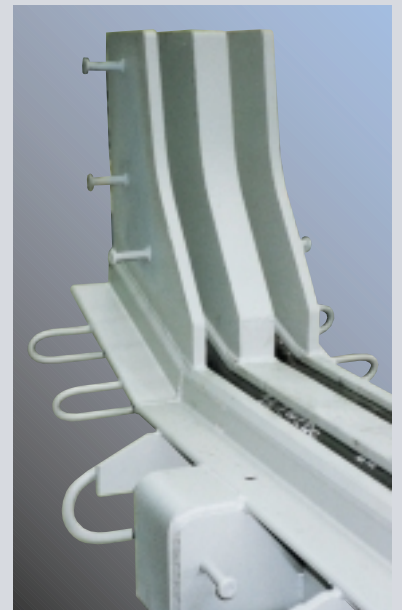

Connection of a modular joint to a single seal joint



Intersection with rail of tram





TGV Viaduct,
Avignon



Storebælt
East Bridge,
Denmark



Bridge over the
River Main,
Nantenbach

Vasco da Gama
Bridge, Portugal



Yang Pu Bridge, China

Oberbaum Bridge, Berlin



Maurer Söhne Head Office
Frankfurter Ring 193, D-80807 München
P.O. Box 44 01 45, 80750 München/Germany
Phone ++49/89/3 23 94-0
Fax ++49/89/3 23 94-306
e-mail ba@maurer-soehne.de
Internet www.maurer-soehne.de

Maurer Söhne Main Branch Office
Westfalendamm 87, D-44141 Dortmund
P.O. Box 30 04 54, 44234 Dortmund/Germany
Phone ++49/2 31/4 34 01-0
Fax ++49/2 31/4 34 01-11

Maurer Söhne Subsidiary Plant
Kamenzer Str. 4-6, D-02994 Bernsdorf
P.O. Box 55, 02992 Bernsdorf/Germany
Phone ++49/3 57 23/2 37-0
Fax ++49/3 57 23/2 37-20